

# Installation instruction C820 exterior cornice

ORAC



UM851 - 06/2024

**Sales Office**  
**ORAC (UK) Ltd**  
Unit 8 City Business Centre  
6 Brighton Road  
Horsham, RH13 5BB  
T 01403 240 102  
uk@oracdecor.com

**London Showroom**  
Casala  
2 Sycamore Street  
Clerkenwell, London, EC1Y 0SF  
T 02045 177 699

More information about Orac Xterio® on [www.oracxterio.co.uk](http://www.oracxterio.co.uk)

# Ready?

Storage conditions



Store profiles at room temperature

Compatible products

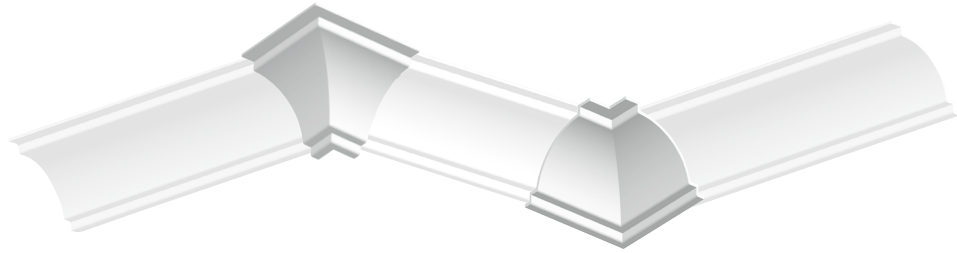

**C820A**  
90° pre-mitred  
outer corner

**C820B**  
90° pre-mitred  
inner corner

# Set?

## DecoFix adhesives

Only full guarantee with DecoFix



Online glue calculator



Seal wall/ceiling



Exterior, non-porous and humid surfaces



### DecoFix Power

Very strong MS-Polymer-based installation adhesive

FDP700 290ml | 7 > 8m

Extra strong MS polymer glue for new build, all exterior applications, non-porous (tiles, glass, ...) surfaces, damp environments and 3D wall covering

- Remove excess with a soap solution.
- Let DecoFix Power dry for 24 hours before painting or before using DecoFiller if necessary.



Joints between mouldings



### DecoFix Ultra

Polymer-based adhesive

FX400 270ml | min. 80m

White, polymer-based adhesive for joints between mouldings

- Use sufficient DecoFix Ultra in each seam joint on 1 side of the already installed profile. Firmly press the profiles together until some adhesive slightly spills out. Be careful not to push all of the glue out of the joint.
- Maintain a small gap (between 0 to 0.2mm). Use a painter's knife to immediately remove excess adhesive (with a soap solution).
- Let DecoFix Ultra dry for 24 hours before sanding/painting or before using DecoFiller if necessary.





3 different ways to install the C820 cornice moulding:

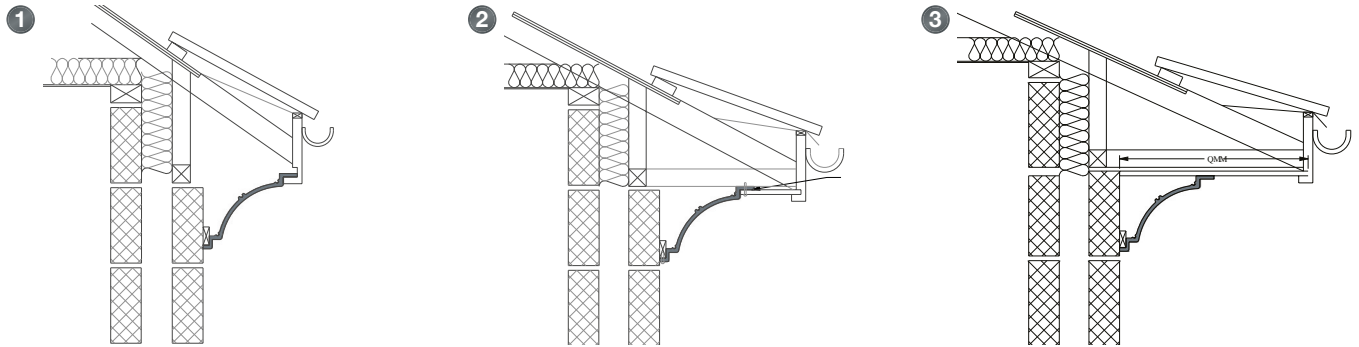

## 1 FIXING DETAILS

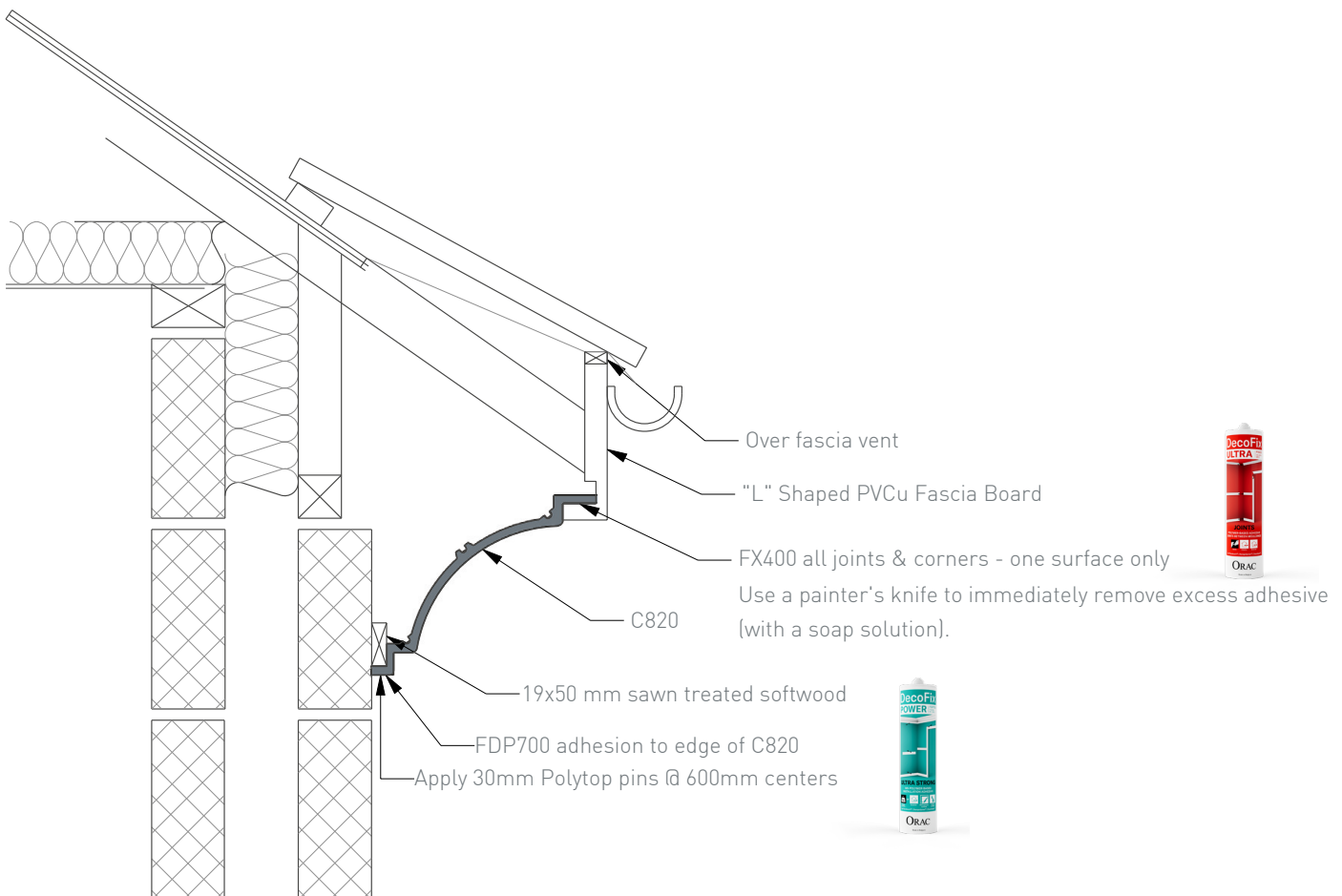

## 2 FIXING DETAILS

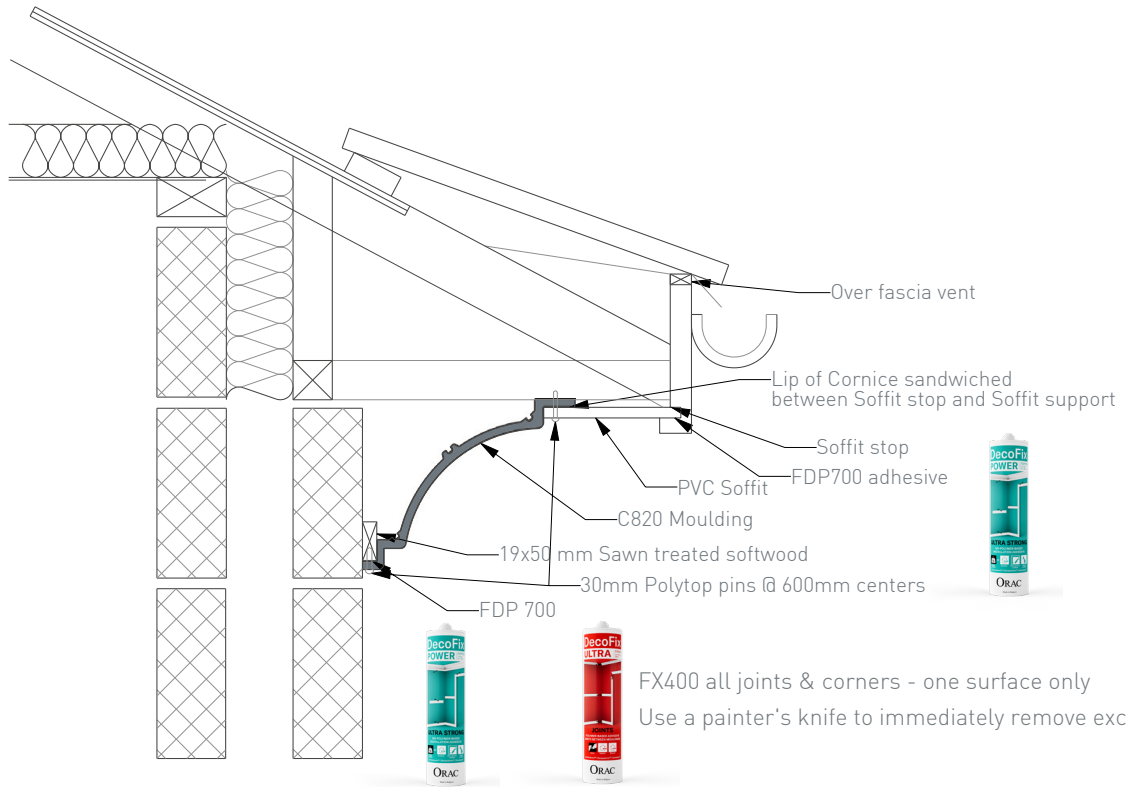

## 3 FIXING DETAILS

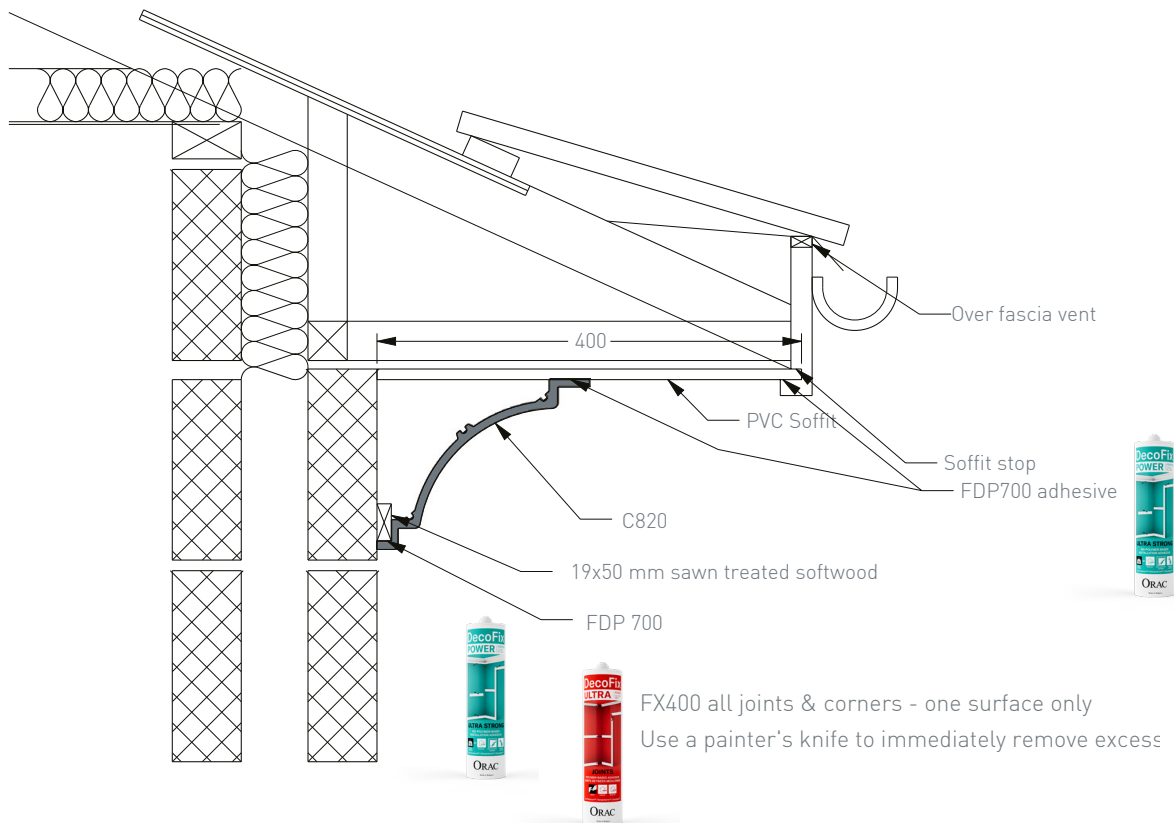

- For an optimal result only use "L"-shaped PVCu Fascia board.
- Apply FX400 DecoFix Extra to all butt joints and C820A/C820B corner elements.
- Use FDP700 DecoFix Hydro for the overall application.
- C820 is pre-finished and should NOT be painted on site.